

بِسْمِ اللَّهِ الرَّحْمَنِ الرَّحِيمِ

(MAPP)

% %)

MAPP

%

(% %

()

MAPP

MAPP

MAPP

MAPP

MAPP

MAPP

MAPP

:



دانشگاه تربیت مدرس
دانشکده منابع علمی آموزشی

:

:

:

:

:

o

ASTM

k n

DARTEC

IZOD

mm () ()

() () ,()

, () ,()

()

() () ,()

, () ,()

()

() () ,()

, () ,()

()

() () ,()

, () ,()

()

%

%

%

%

PP%40-%60 WF-MAPP%2 h30 , PP%40-%60 WF-MAPP%0 h 30

() () ,()

, () ,()

()

%

%

%

%

%

%

%

%

%

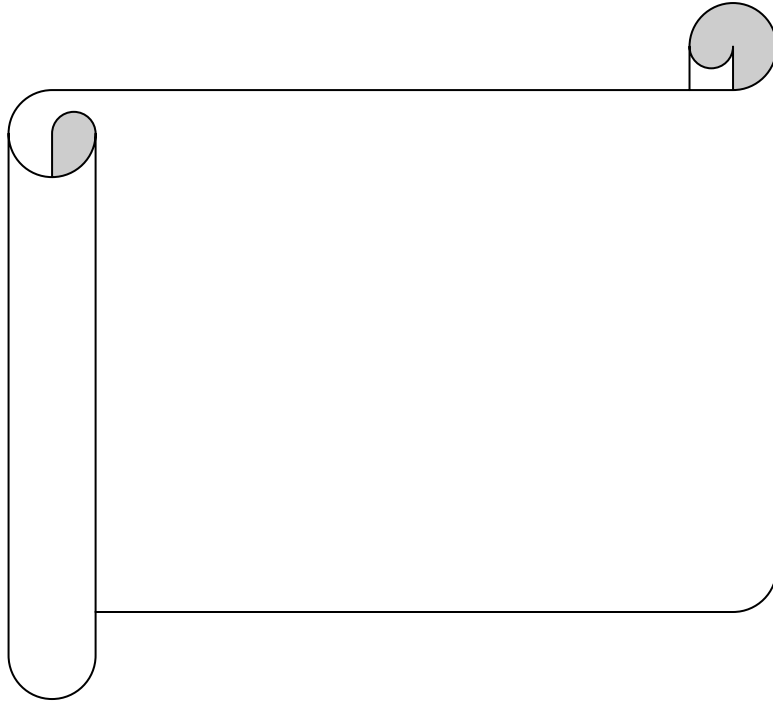

(WPCs)

...

.(Youngqist)

.(Sreekala Mechraoui)

.()

Mankowski)

.(Morrell)

¹Wood Plastic Composites (WPCs)

() Clemons Ibach

(Stark Ebrahimi Tajvidi Dobrev)

Kazemi Najafi) () ()
(Clemons Oksman Gassan Bledzki

.(Marcovich)

(HDPE)

() Faezipour Kaboorani

.(Militz Tjeerdsma)

Mohebb)

² HydroThermal

(Garrote Sanaei Mohebbi Sundqvist
(Hydrothermal)

(PP)

(MAPP)

()

Lu Morrell Wang Huang)
MAPP (Tjong Stark Ralph

Adhikary)

(Kazayawoko Ralph Lu

Li Adhikary Tjong)
(Morrell Wang Matuana

³ PolyProPylene (PP)

⁴ Maleated PolyProPylene (MAPP)

()

--

(MAPP)

(MAPP)

--

MAPP

--

()

()

MAPP

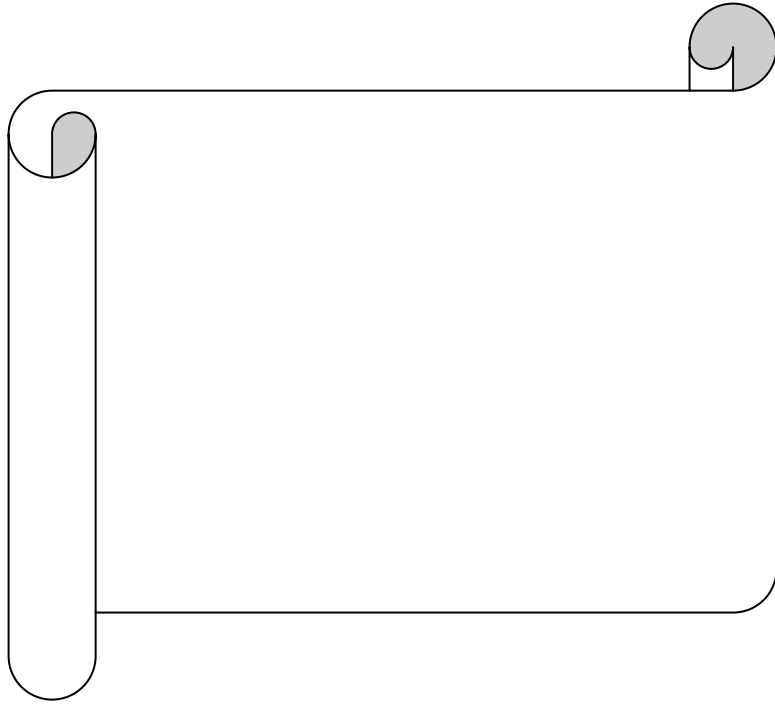

()

()

()

٪
:

MAPP %

٪

(Ebrahimi Tajvidi)

() Stark

%

%

%

Lin

()

.(Morrell Wang)

(Wolcott Chowdhury)

MAPP

MAPP

(Ralph Lu Adhikary)

MAPP

(Demir)

(MAPP)

(MAPE)

(Hristov, Keener)

(Kazayawoko)

(Zhang)

(Tserki, Simonson, Rowell)

(Crystallization)

Wallenberger Gümüşkaya Yildiz

(FT-IR) (Weston, Militz, Tjeerdsma)

()